

iQ™

MAGNIFIER

U25100

Fact Sheet

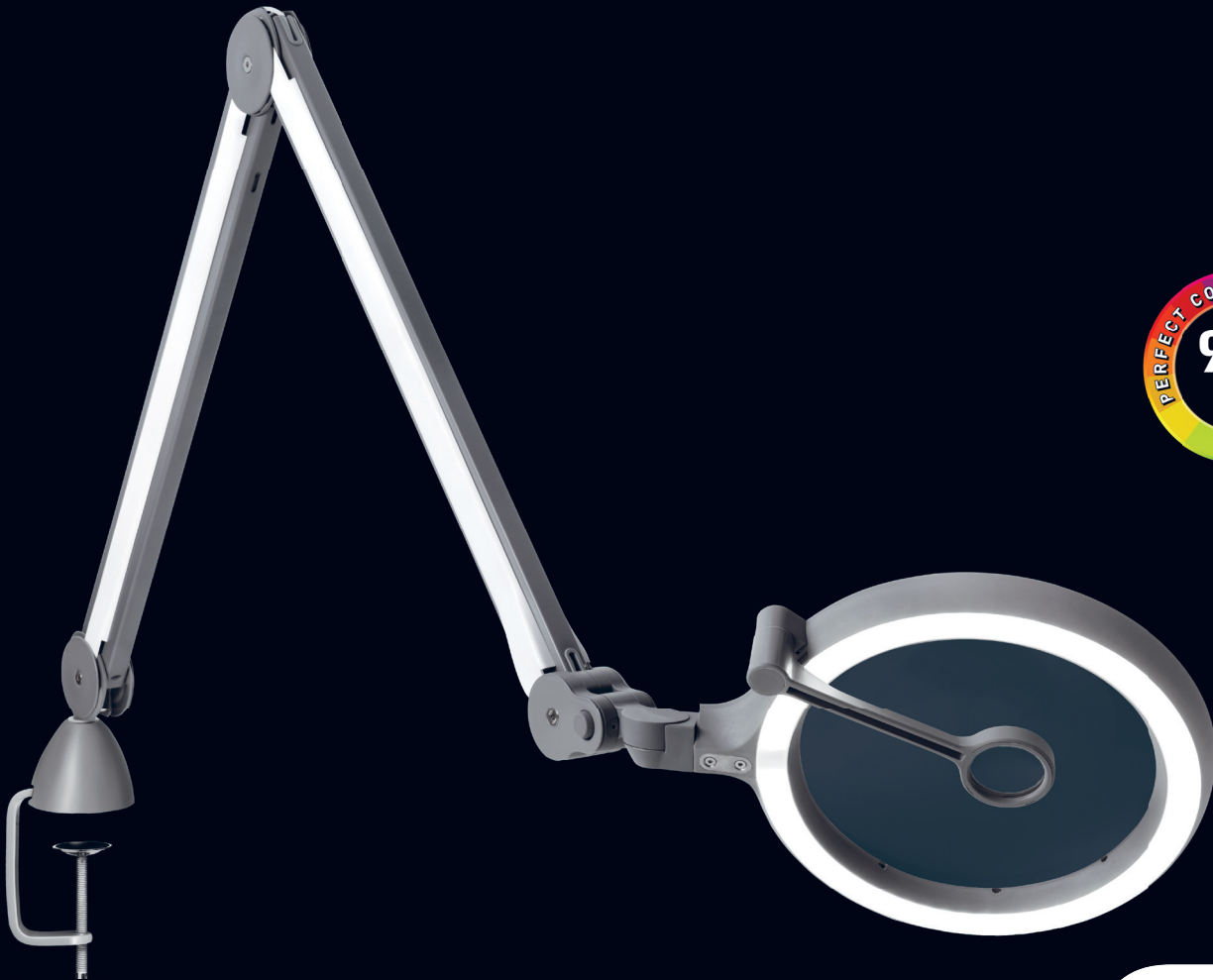

The iQ magnifier has a 7" lightweight acrylic lens offering a large field of view. The magnifying head moves freely and holds any position - maximising horizontal and vertical movements. The heavy-duty internally sprung arm provides good horizontal reach and will stay in place. A 12 diopters (4.0X) magnification lens mounted on a swing arm is also included. Lateral protections help you keep it clean. The magnifier is fitted with a removable lens protector.

LED 6,000K daylight

6,300 Lux at 15cm (6")

4 brightness levels



LIGHT QUALITY



ERGONOMICS



DESIGN

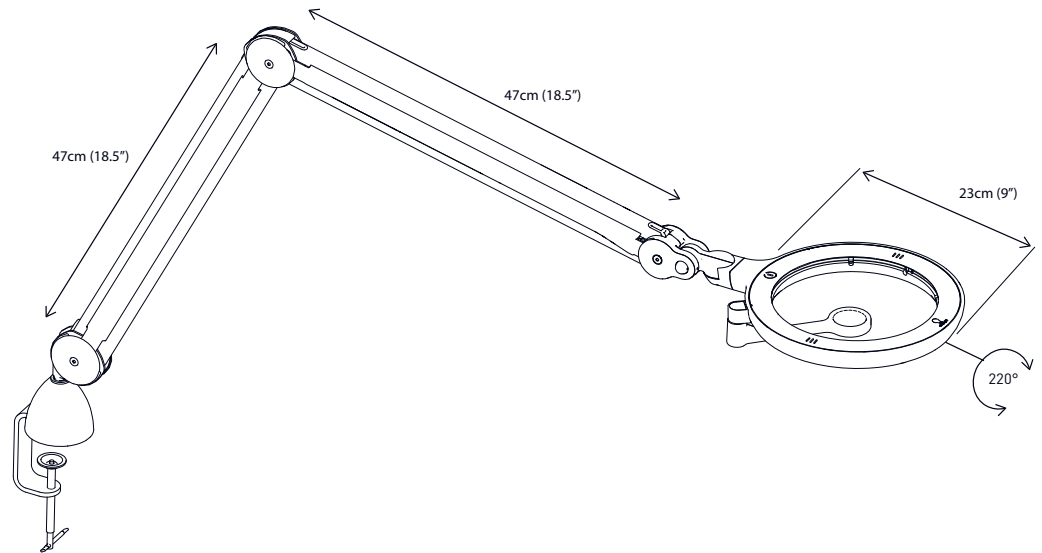

FEATURES

- Acrylic lens with anti-scratch coating, removable lens protector
- Daylight 6,000K and 95+ CRI to see colors accurately
- 3 diopters (1.75X) with 12 diopters (4.0X) swing arm lens
- Covered arms with internal springs
- Long reach 46.5"
- 4 brightness levels

SPECIFICATIONS

Product information

Weight	8 lb
Color	Grey / White
Cable Length	78"

Light output

Light source	LED
Lumens	814 lm
Lux at 15cm (6")	6,300
Color temperature	6,000K
CRI	95+
Energy consumption	12W

Packaging information

Height	24.4"
Width	20.8"
Depth	4"
Packed weight	11 lb
Products per master carton	2