



V0.969-S16

Particle Trap[®]Cube Operation Manual

Thank you for purchasing the Particle Trap Cube (PT Cube). Although this device is not specified as a high voltage device according to electrical equipment standards, it uses high AC voltages and we therefore ask that it be operated correctly after carefully reading this instruction manual. Please store this manual carefully and utilize it appropriately when required.

Safety Precautions

Because this device uses high internal voltages, there is the possibility that incorrect usage can lead to physical injury or damage to the product. This company does not accept any responsibility for uses outside the parameters of the product specifications or failure to follow these safety precautions.

 Warning	<p>This device does not conform to explosion-proof specifications. Do not install or use it in locations or atmospheric conditions where flammable gases or solvent are handled. Doing so may result in fire or explosion.</p>
	<p>Because high voltages are applied to the emitter pin, keep it away from conductive objects such as your fingers and body, wires, tools, etc. It may cause electrical shock or damage.</p>
	<p>Because the tip of the emitter pin is sharp, take sufficient care when handling it. It may cause injuries.</p>
	<p>Do not under any circumstances disassemble, repair, or modify this device. Doing so may cause an accident or damage.</p>
	<p>Connecting, installing, and maintenance must be with the power turned off. Failure to do so may cause accidents or damage.</p>
	<p>Because the fan rotates at high speed when the power is on, do not insert small objects etc. between the gaps in the guard. Doing so may cause an accident or damage.</p>

 Note	<p>Because this device incorporates devices that generate high voltages, avoid installing it in wet, oily, hot, and humid locations. In particular, avoid using it in locations of high humidity and condensation.</p>
	<p>Be sure to ground the device. Failure to do so can cause deterioration of its neutralizing characteristics, malfunction, and damage.</p>
	<p>If the product does not work anymore or is no longer required, dispose of it in the appropriate manner as industrial waste.</p>
	<p>Carry out wiring and ducting correctly. If done incorrectly, it can lead to diminished performance and damage.</p>
	<p>Because this device generates high voltages, management of operation, maintenance, etc. should be carried out by a sufficiently knowledgeable and experienced person.</p>

1. Overview of the Product

This device is a static charge/cleaning device that is immediately useful for removing particulates attached to charged work pieces. Contaminants attached to work pieces are removed by blowing compressed air from nozzles installed at the top and bottom of the main unit, and the work piece and particles are neutralized by a separately installed ionizer to prevent reattachment. Clean air is discharged through a filter at the back of the unit by a high-power suction fan, trapping particles in the filter without scattering particulates back into the clean room.

2. System Structure

The device is used by supplying 100 to 240V AC via the supplied power cable and compressed air via the supplied filter/regulator with dual-stage filtration.

3. Items Included with the Device

Check whether any of the following items are missing, whether there are any irregularities, and whether they have been damaged during transit before use. If there is any damage or the product does not operate correctly, please contact **Static Clean International**.

- | | | |
|---|--|---------|
| ① | PT Cube main unit | : Qty 1 |
| ② | Instruction Manual: This document | : Qty 1 |
| ③ | Power cord | : Qty 1 |
| ④ | Work inlet covers | : Qty 3 |
| ⑤ | Replacement filter | : Qty 1 |
| ⑥ | 3/8" NPT Male x Female Elbow, Nickel Plated | : Qty 1 |
| ⑦ | 3/8" NPT Male x 1/4" Industrial Quick-Disconnect Fitting | : Qty 1 |

4. Specifications

Product Name		Particle Trap®
Model		PT Cube
Ratings	Voltage	100V ~ 240VAC (50/60Hz) ±10%
	Consumption	240W max.
Ionizer	System	HDC-AC
	Ion Balance	Within ±30V*1
	Neutralizing Performance	1.0 sec or less (at 87 psi) *1
Fluid		Air (clean dry air)
Air Pressure Range		29~87 psi *2
Air Connection		3/8" NPT Female Port 3/8" NPT Male x 1/4" Quick-Disconnect Fitting Included
Blow Nozzles		Upper surface: 2 Lower surface: 1 (angles of upper surface nozzles are adjustable)
Filter Performance		Able to trap at least 98% of particles of at least 10µm
Settable Functions	Blow pulse settings	1 Hz, 3 Hz, 5 Hz, 10 Hz, Cont
	Blow interval settings	3 sec, 5 sec, 10 sec, 15 sec, Real
	Fan RPM settings	Non-stepped variable: 495 cfm (max)
Air Consumption	At 45.3 psi pressure	9.5 cfm (270l/min ANR) (when pulse setting is 'Cont')
	During standby	0 cfm (0l/min ANR)
Noise	With fan RPMs at min.	51dBA*3
	With fan RPMs at 50%	74dBA*3
Size (not including protruding parts)		8.9" W x 14.2" H x 15.7" D (225 mm W x 360 mm H x 400 mm D)
Weight		~22 lbs. (10 Kg)
Environment	Temperature	0 ~ 40°
	Humidity	15 ~ 85% (without condensation)
	Max. altitude	2000 m

5. Exterior, Names and Functions of Components

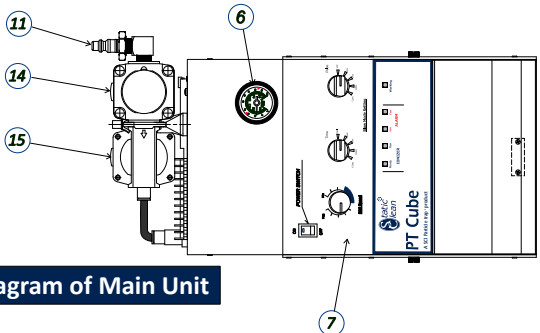

External Diagram of Main Unit

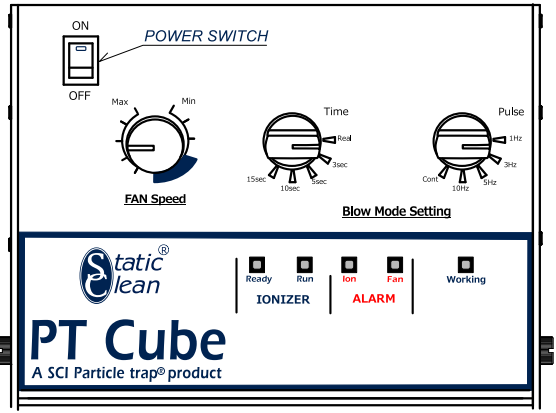
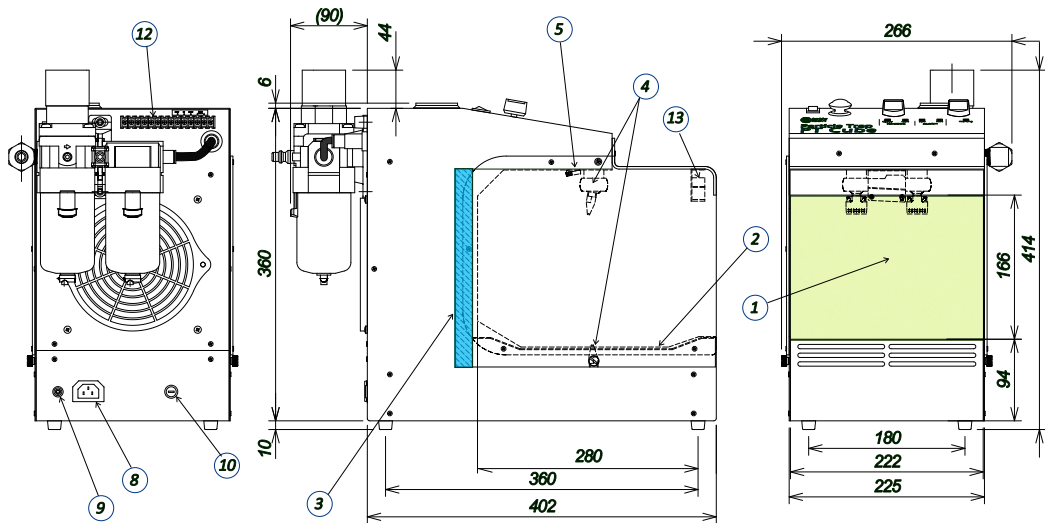

Diagram of Setting/Display Panel



5-1 Explanation of Main Unit Components

#	Component	Description
1	Work inlet	Insert the work to eliminate static charges and clean.
2	Main unit perforated floor	Detach this when cleaning the inside of the main unit. When detaching, remove the knurled screws (one on each side) in the sides of the main unit for holding this floor in place.
3	Filter	Replaceable filter to trap particles
4	Blow nozzle	Two blow nozzles are arranged at the top and one at the bottom. The angles of the two blow nozzles at the top are adjustable, and their angles can be adjusted as desired to match the shape of the work piece.
5	Ionizer	A static elimination ionizer nozzle
6	Air pressure gauge	Display the air blow pressure. This device can be used within the range of 29 to 87 psi.
7	Setting/Display Panel	Displays the various settings and operations. Details are described below.
8	Power cord inlet	A connector for supplying AC power. Connect the supplied power cable here.
9	Ground terminal	A terminal for grounding. You can connect an M4 terminal.
10	Fuse box	The power supply fuse box.
11	1/4" quick coupler	A coupler for connecting compressed air. Connect using a 1/4" ID(min) air supply line/pipe.
12	Terminal Strip	For sensor 'Eye' connection
13	Sensor "Eye"	Detect the work object and start air blow
14	Primary Filter	Filter with 5-micron element and condensate bowl
15	Secondary Filter	Mist-Separator Filter with 0.3-micron element and condensate bowl

5-2 Setting/Display Panel

Component		Description
Power switch		The main switch of this device.
Blow mode setting	Pulse	Sets the pulse of the air blow. You can select 1Hz, 3Hz, 5Hz, 10Hz, or continuous air blow ('Cont').
	Time	Sets the air blow time. Set 'Real' mode to turn the blow on and off by means of a sensor; OR set to 3 sec, 5 sec, 10 sec, or 15 sec continuous air blow from when sensor first detects (sees) a part
Fan speed		You can adjust the rotational speed of the suction fan. When setting toward MIN, speed decreases, and when setting toward MAX, speed increases. The higher the fan speed the stronger the suction capability, but operating noise increases proportionally. Recommended adjustment position is within the blue zone.
Ionizer	Ready lamp	This is illuminated when static charge and particle elimination preparation is complete.
	Run lamp	This is illuminated when the ionizer is running. The ionizer operates in conjunction with the air blow and runs until 3 seconds after the air blow finishes.
Alarm	Ion lamp	This is illuminated when an irregularity occurs in the ionizer. When this is illuminated the device will not operate until reset.
	Fan lamp	This is illuminated when an irregularity occurs in the fan. When this is illuminated the device will not operate until reset.
Working lamp		This is illuminated when a work piece is detected and air is blowing. It blinks at the pulse speed when the 'Blow Mode' setting is set to 'Pulse.'

6. Installation, Wiring, and Air Ducting

6-1 Before Installing

- Install the device in a rigid flat location such as a work bench etc. Avoid installing it in unstable locations.
- Be sure to connect the ground terminal of the power cord or the ground terminal of the main unit to ground.
- Use the device indoors only. Do not use it in oily or wet locations, locations where flammable gases and solvents are handled or locations with such atmospheres, or hot or humid locations.
- Check that the power of the main unit is turned off or the regulator is closed when connecting the power supply and connecting the air line.

6-2 Wiring

Supply 100 to 240 VAC (50/60 Hz) to the device with the supplied power cord.

6-3 Air Ducting

Air pressure gauge reading	Max. air flow during operation
29psi	6.4 cfm (180l/min ANR)
43.5psi	9.5 cfm (270l/min ANR)
58psi	11.5 cfm (325l/min ANR)
72.5psi	13.1 cfm (370l/min ANR)
87psi	15.0 cfm (425l/min ANR)



Connect a compressed air line to the filter/regulator assembly at the back of the unit.

- Install (1) 3/8" NPT Male x Female Elbow (shipped loose with PT Cube) into the 3/8" NPT Female port of the filter regulator, oriented up, down or rear-facing as desired after tightening with a wrench. Be sure to use Teflon tape to prevent leaks.
- Install (1) 3/8" NPT Male x 1/4" Industrial Quick-Disconnect Fitting (shipped loose with PT Cube) into the Female port of the elbow, then tighten with a wrench. Be sure to use Teflon tape to prevent leaks.

NOTE: you can plumb straight into the filter/regulator port if you prefer

- Use clean, CDA (Clean, dry air) as the air supply. Check that a dryer and filter are attached to the air equipment you are going to use, and if not attached, attach them.
- Check that the compressor has the following flow rates and use a compressor that has sufficient leeway.
- This system has a regulator with filtration installed on the back of the main unit for control of pressure (psi) used to clean your parts
- **6-4 Attaching the Work Inlet Cover**
 - Work inlet covers are included for preventing scratching when a work piece hits the work inlet of the device. Attach and use them as appropriate.
 - Two types of black work inlet cover of different lengths (one long and one short) are provided. Fasten them at the attachment positions corresponding to their lengths.
 - The work inlet covers are held between resin plates, but if these come off during use, reattach them using adhesive glue (supplied separately).

*Attach the work inlet cover to the transparent resin portion of the main unit inlet.

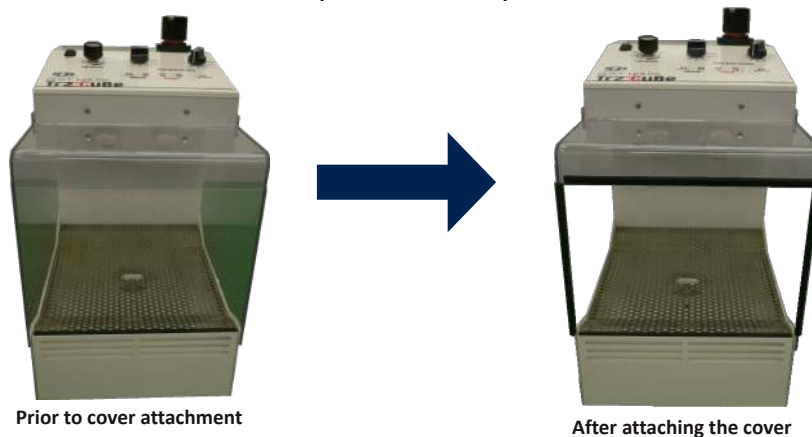

7. Operation

7-1 Procedure When Starting Operation

- ① Install the device in a location with a flat top and carry out wiring and air connection.
- ② Open the compressor valve and supply air to the device. Operate the air equipment installed outside the device to adjust the air pressure supplied to the device. (between 29 psi and 87 psi).
- ③ Turn the power switch of the device on, check that the 'IONIZER' - 'Ready' lamp on the main unit display panel is on, and insert a work piece. The sensor will detect the work piece and operation will begin.
 - There is a warm up time of about 5 seconds from when the power switch of the device is switched on, during which time all of the lamps in the display panel of the main unit are illuminated.
 - The fan runs when the power switch of the device is switched on.
 - When blowing, the 'Working' lamp is illuminated in conjunction with the blow pulse. The ionizer also works in conjunction with the blow and runs until 3 seconds after the blow is turned off. The 'RUN' lamp is illuminated while the ionizer is running.
- ④ Adjust the fan speed, pressure, time and pulse of the system to optimize cleaning based on the amount of particles attached to the work piece.
 - Although the device has a built in photoelectric sensor, it also has 'Time' settings for blowing continuously for 3 seconds, 5 seconds, 10 seconds, and 15 seconds after the sensor activates once, for when work detection is difficult due to the work material (transparent work pieces etc.) or you want to manage the blow time. Configure these settings accordingly.
 - When the fan speed setting is fast, the suction capability increases greatly, and the operating noise becomes correspondingly loud. The recommended setting is within the blue zone of the fan speed knob. Sufficient suction power also is exhibited with the main unit Air pressure gauge reading at 87 psi.

7-2 Procedure When Finishing Operation

- ① Turn the power switch of the device off.
- ② Close your air valve from your 'house' compressed air system (not included with this system) to prevent a leak or wasted energy.

7-3 Alarm Cancellation Procedure

The device has a function for displaying on the main unit display panel when fan rotation stops or there is an irregularity in the ionizer. If the 'ALARM' display is illuminated, you can refer to **9. Troubleshooting** of this manual and reset the main unit by turning the power on again after resolving the irregularity.

- While the 'ALARM' display is illuminated all operations of the device are stopped and remain stopped until reset.

8. Maintenance

- The filter is disposable. Since the rate at which the performance of the filter decreases varies according to frequency of use and the amount of particles on work pieces, replace it appropriately according to the state of usage. If clogging becomes severe, suction capability will decrease. Be sure to only use p/n PTCFLT replacement filters, sold in packages of 5.
- If by chance water or oil lands on the device despite having installed it in a water- and oil-free location, switch off the power as soon as possible and wipe it down with a dry rag or cloth. Take care particularly around high voltage areas and their peripheries.
- If dirt adheres to the emitter pin of the ionizer or its surrounding nozzle, the neutralizing effect is reduced. To prevent reduction of the neutralizing effect, regularly clean the emitter and nozzle.
- When carrying out maintenance, be sure to disconnect the unit from power and compressed air. Unintended operation can cause injuries, electrical shock, or damage to the unit.

8-1 Filter Replacement Procedure

- ① Check that the power switch is turned off and the air pressure gauge reading is 0 psi.
 - ② Detach the filter in the work entrance direction and replace it with a new one.
- After inserting the filter between the main unit central plate and the metal mesh on the far side, pull the tab at the top of the main unit and insert it so that it is firmly attached to the metal mesh portion on the far side.
 - The side of the filter that is not glossy is the front. The front is the workspace side.

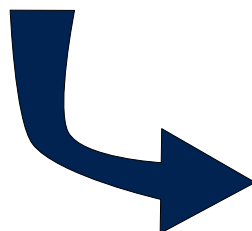

8-2 Ionizer Cleaning Procedure

- Although a cover is attached so that the emitter pin cannot be touched, the tip portion of the emitter pin is very sharp. Use caution when handling or it may result in injury.
- ① Check that the power switch is turned off and the Air pressure gauge reading is 0 psi.
- ② Wipe off the inside of the ionizer nozzle, the tip of the emitter pin and any other dirty parts with a Q-tip dampened with IPA (isopropyl alcohol).
- Dry the alcohol sufficiently after cleaning.

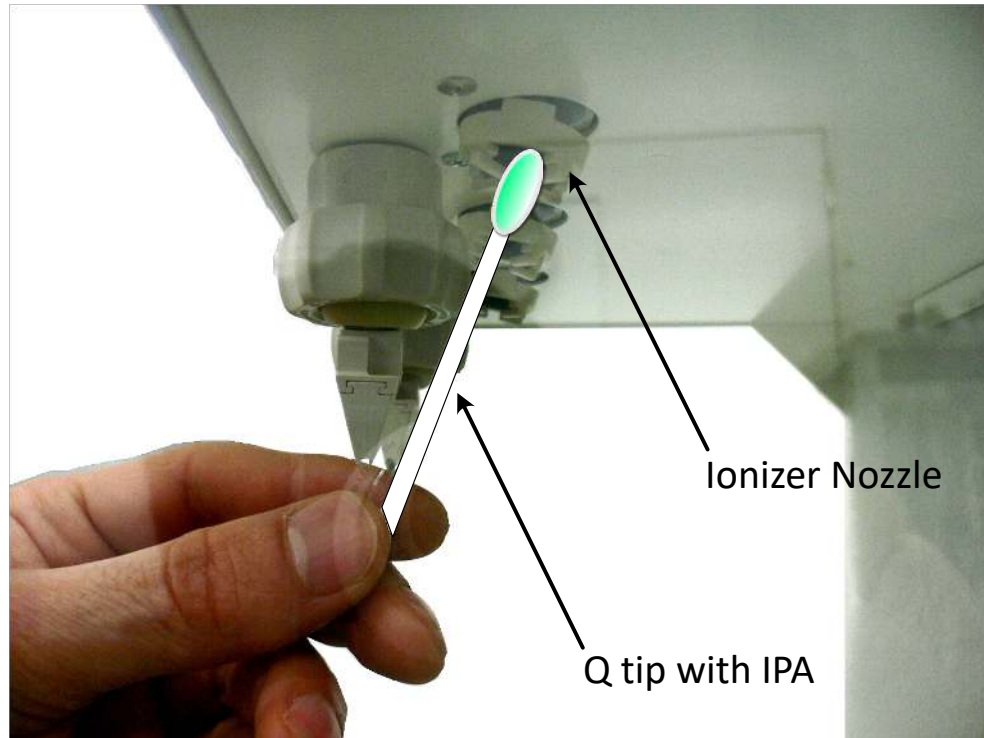

8-3 Workspace Cleaning Procedure

- Depending on the usage condition of the workspace, it may become dirty. Therefore, in order to maintain a clean workspace, it is recommended that you clean it regularly.
- ① Check that the power switch is turned off and the regulator pressure is 0 psi.
- ② Remove the knurled screws in the sides of the main unit (one on each side).
- ③ Remove the perforated floor.

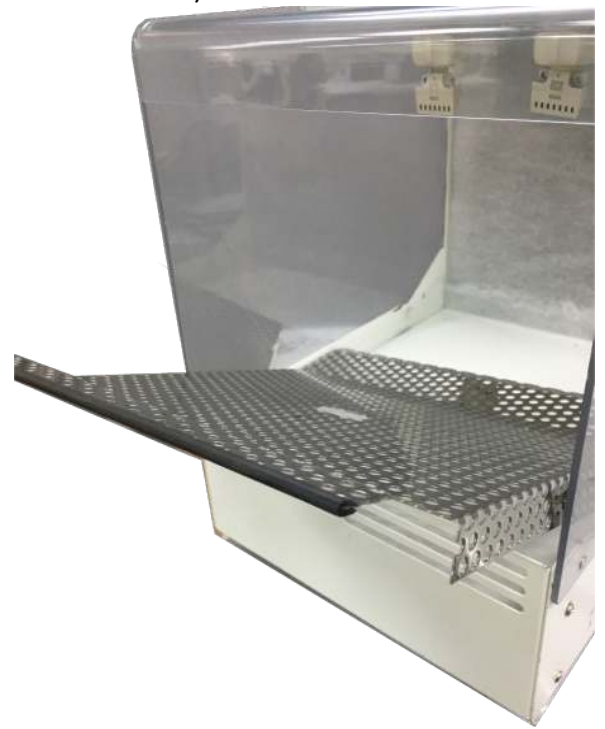

- ④ Wipe off any dirt on the workspace with a rag etc. containing alcohol. If you cannot remove fine dirt, you can also blow it clean with compressed air etc.
- ⑤ Re-attach the perforated floor (the side with black rubber attached should face toward you).
- ⑥ Insert the knurled screws in the sides of the main unit.
 - If you do not reinsert the knurled screws the photoelectric sensor may not operate correctly.

9. Troubleshooting

- The power will not turn on.
 - Check that the wiring and power supply are set up correctly.
 - The fuse may be blown. Check the fuse box in the rear side of the main unit.
 - *Compatible fuses are $\Phi 6.4 \times 30\text{mm}$, 250V, 10A.**
- Air blow doesn't occur.
 - Check that the compressor air is being supplied correctly.
 - Check that the regulator of the device is adjusted correctly.
 - Check whether the 'ALARM' - 'ION' or 'FAN' lamp is illuminated.
 - The neutralizing effect is unsatisfactory.
 - Check whether the emitter pin or its surroundings are dirty.
 - Check that the ground of the device is reliably grounded.
 - Check that there is no water or oil in the compressed air being supplied to the device. (Check that conditioners such as an air filter and dryer are attached.)
 - 'ALARM' – 'ION' is illuminated.
 - Check whether the emitter pin or its surroundings are dirty.
 - Check that the ground of the device is reliably grounded.
 - Check that there is no source of noise in the vicinity of the device.
 - 'ALARM' – 'FAN' is illuminated.
 - Check that no foreign objects are in the fan portion of the main unit.

10. Options

- Replacement 10-micron exhaust filters (x5): p/n PTCFLT
- Replacement 5-micron filter/regulator element: p/n AF40-060S
- Replacement 0.3-micron secondary filter element: p/n AFM40P-060AS

IF YOU HAVE STATIC, WE HAVE SOLUTIONS.

