

# Instruction Manual

## JAG-IV JetAURA Ionizing Gun



Thank you for purchasing JAG-IV JetAURA. As to the use of this unit, you must have sufficient considerations after reading this manual carefully because it deals with alternating currents with high voltage of 2500V, although the units is not stipulated as high-voltage equipment in the electric equipment standard. Please read this manual before using the unit in order to fully understand its functions. Also make sure to store this manual so that it can be referred to in the future.

### Warning

- This unit is not specified as an Explosion-proof Type. Do not use this unit at a location or an atmosphere, in which combustible gas or solvent is handled, or else ignition or explosion may occur.
- This unit emits ozone. Do not use in an enclosed space. The emitted ozone may be detrimental.
- A high voltage is applied to the discharge needle. Do not allow any conductive material, including your finger, any part of your body, wire or any tool to get close to the discharge needle, or an electrical shock accident or a malfunction of the unit may occur.
- The tip of the discharge needle is sharp, be careful not to touch the discharge needle.

## 1. Safety Precautions

### 1.1 Symbols on the main unit

- The apparatus is marked with this symbol when the user should refer to the instruction manual in order to protect against harm to the operator and to protect the apparatus against damage.
- Indicates dangerous voltages.

### 1.2 Safety

Read this instruction manual before installation, wiring, operation, or maintenance of the unit in order to achieve maximum performance. Improper use of this unit may cause an accident resulting in injury or may lead to a malfunction of this unit. Our company will not be held liable for any usage outside this unit Specifications or any accident caused by noncompliance with the Safety Precautions.

- Danger** Failure to follow instructions may lead to serious injury.
- Warning** Failure to follow instructions may lead to injury.
- Caution** Failure to follow instructions may lead to product damage (product malfunctions, etc.)

## 2. Precautions for CE Marking

This unit complies with the following EU Directives and EN standards.

- EMC Directives: EN61000-6-2 / EN61000-6-4
- Low-voltage Directive: EN61010-1
  - Overtoltage Category (Installation Category): I
  - Pollution Degree: 2
- Be sure to use a supplied AC adapter ( JAG4-PA ).
- Applicable standard: EN60950-1
- Overtoltage category: II
- Pollution Degree: 2

## 3. Outline

- This unit is an air gun type ionizer you hold with your hand and to use it freely.
- This unit is spraying ionized air on a charged object, neutralizing the static electricity of a charged object quickly and effectively. Dust which has adhered to the charged object with static electricity is removed, and recontamination is prevented.
- The high-voltage power supply and the solenoid valve are internal to the unit. External controllers are not necessary.
- Ionized air can be constant or pulsed(5Hz or 10Hz). By spraying pulsed ionized air, you can increase the dust removal effect and save energy on air.
- Equipped with high brightness LED for lighting. Useful for checking foreign objects such as dust.

## 4. Specifications

### Outlook

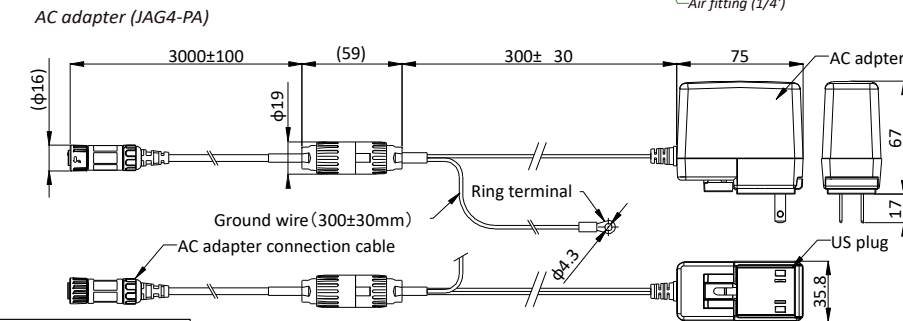
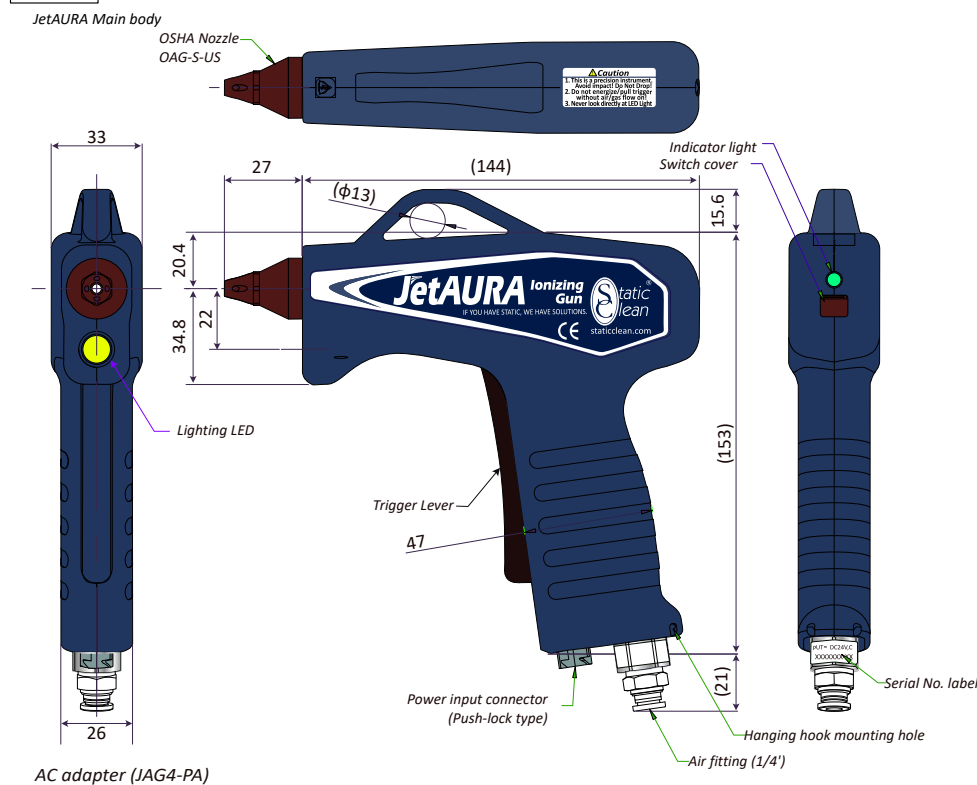

### List of Specifications

*Ionizer Gun	
Model	JAG-IV JetAURA Ionizer Gun
Discharge Method	High frequency AC corona discharge method
Input voltage	24 V DC ± 5%
Capacity	4.8 VA
High voltage output	AC 2,500V approx. (3pF, 100MQ)
Applicable fluid	Air (dried clean air) or *Nitrogen
Air pressure range	7.25 to 87.02 psi (0.05 to 0.60 MPa)
Supplied air flow	13.42 cfm (380 l/min (ANR)) or less
Dimensions (mm)	6.73"W x 1.29"D x 6.63"(171W x 33W x 168.5H (mm)) (Not including protruding parts)
Weight	310 g approx. (Not including cable)
Environment	Indoor, Altitude up to 6,561ft (2000 m)
Ambient temperature	32 to 104° F (0 to 40 °C)
Ambient humidity	15 to 65 % (No condensation allowed)
Indicator LED	Green: Connect to power supply (Lever OFF) Blue: Normal high voltage output (Lever ON) Red: Abnormal high voltage output
Ozone Level	0.04 ppm or less (by air pressure 29.00psi (0.2MPa) and 7.87" (200 mm) apart from the nozzle )
Material	Main body: PBT, Nozzle: PPS
Accessories	AC adapter connection cable 118.11" (3 m), AC adapter with US plug, UK plug, EU plug, 1/4" Push-in X 1/4" NPTF Male-thread fitting, 1/4" OD x 78" (2m) black polyurethane air tube, Hanging hook (SUS), JAG-ERT(Discharge needle attachment/detachment tool), Instruction manual (This manual)

*AC adapter	
Model No.	JAG4-PA
Rated input	100 to 240 V AC (50/60 Hz)
Rated output	24 V DC Max1.0 A
Weight	230 g approx.

\*When using nitrogen gas, please replace it with a dedicated nitrogen compatible nozzle (OAG-N-S-US).

## 5. Static Removing Characteristics

### Static Removing Characteristics

Air pressure PSI [Mpa]	14 [0.1]	29 [0.2]	44 [0.3]	58 [0.4]	73 [0.5]	87 [0.6]
+ Static charge removal time [sec.]	0.3	0.2	0.2	0.2	0.2	0.2
- Static charge removal time [sec.]	0.3	0.2	0.2	0.2	0.2	0.2
Ion balance [V]	-10 to +10 V					

\*Typical value at a distance of 150 mm from the nozzle. (before shipment)

\*Measuring instrument: Charged plate monitor (Plate size 150 mm x 150 mm, Electric capacity 20 pF)

\*Static charge removal time: Decay time from ±1000 V to ±100 V.

### Warning

- Be sure to turn OFF the power and air before installing, wiring, or piping the unit.

### Caution

- Be sure to earth the ground wire of the AC adapter. Incomplete grounding may cause damage to the main unit and AC adapter. In addition, it causes a decrease in static elimination performance.
- For installation or using of this unit, pay attention to the contamination by oil/water, high temperatures or high humidity. Especially, avoid a place subject to dew condensation.
- If the air includes water and oil, inside of the main unit or the nozzle gets dirty, the ability to remove electricity is lowered, or causing deterioration of the main unit.
- Install the unit and AC Adaptor in a safe, secure manner, to prevent damage to the equipment.
- Do not remove the air fitting at the bottom of the main body and attach another fitting.

### Installation

- There is a hanging part at the top of this unit, but you can change the hanging direction of the main unit by attaching the included hanging hook to the hanging hook mounting hole at the bottom of the main unit. If necessary, use hanging hooks.
- Insert the included hanging hook into the hanging hook mounting hole at the bottom of the main unit as shown in the figure below.

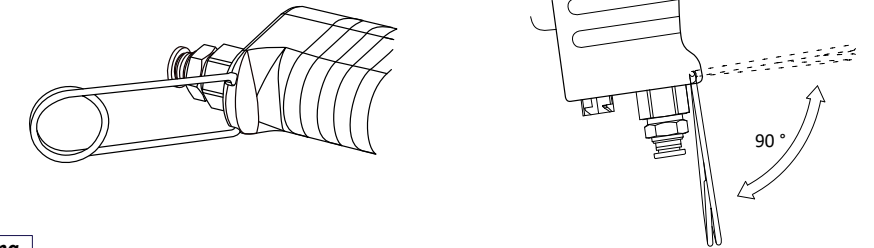

### Wiring

Carry out wiring for the main unit and the AC adapter in accordance with diagram below.

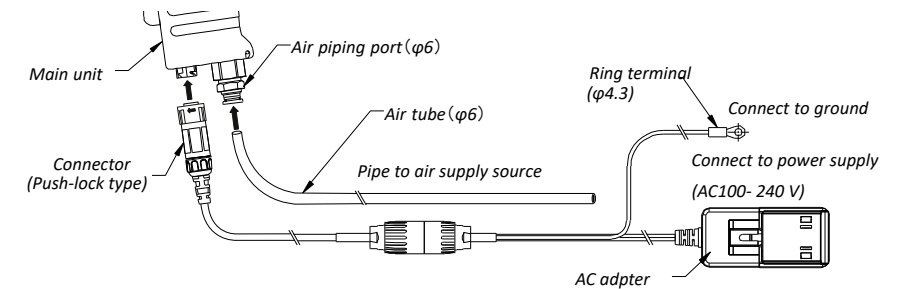

- Connect the push-lock type connector of the AC adapter to the power input connector of the main unit.
- Connect an AC adapter to a power supply (AC100-240 V 50/60 Hz).
- When you connect the cable to the main unit and turn on the power to the AC adapter, the indicator light on the main unit lights up in green.

### Piping

Carry out piping for the main unit in accordance with diagram above.

- Install an air tube (outside diameter 1/4") to the air piping port of the main unit.
- Supply the main unit with clean, dry compressed air (not containing any water or oil).
- Regulate supplied pressure from 5 to 87 psi (max). We offer an optional ASFRG14C AIR FILTER/REGULATOR & GAUGE SYSTEM with a 5.0-micron primary and 0.01-micron secondary filter to keep your materials, products and this JetAURA Gun clean.
- Supplying pressure over 87psi may prevent a) the solenoid valve inside the unit from opening, b) the unit from operating normally, causing the RED Alarm LED to illuminate. If this occurs, lower the pressure to the recommended 7~87 psi (max) Range.



### Air fitting replacement

- This unit is equipped with a quick fitting for 1/4" air tube. If necessary, this fitting can be replaced.
- When replacing the air fitting, be sure to hold the bulkhead fitting and turn the air fitting to remove it. If you try to remove the air fitting by holding the main body rather than the bulkhead fitting, the bulkhead fitting may come loose and cause the unit to malfunction.
- In the same way as when removing the air fitting, when installing the air fitting, hold the bulkhead fitting and turn the air fitting to install it.
- There is a serial number label on the bulkhead fitting, so be careful not to damage the label when replacing the air fitting.

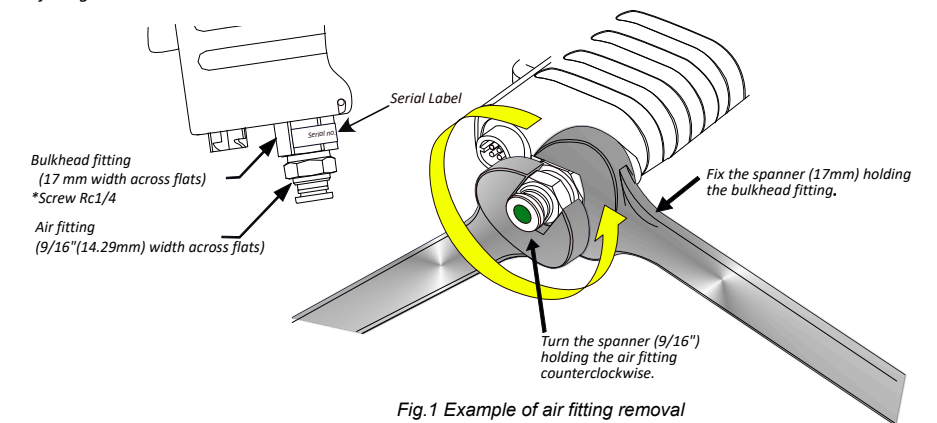

Fig.1 Example of air fitting removal

## 7. Operation

### Warning

- Do not operate the main unit with the nozzle aimed at a human body, especially to the face or to the eye of a person. This may cause serious injury to the person.
  - Only apply the power of this unit when supplying air. Otherwise, the ozone concentrations inside the main unit would increase due to electric discharge, which may cause detrimental effect on this unit and its surroundings.
  - Do not let the nozzle of the main unit touch conductive or live parts, because it is connected to the inside circuit. It may cause electric shock and abnormal operation.
  - Since piezoelectric ceramics is built in to main unit, do not drop or shock. It can cause damage.
  - Do not use other nozzles than ours, and not remodel nozzles. Such use or conversion could result in poor function, shutdown, or damage.
  - When using this unit, be sure to lock the discharge needle unit.
  - Do not look directly at the lighting LED.
  - Do not use the lighting LED continuously for long periods of time.
- This product emits ozone into an atmosphere. Do not use this product in an enclosed space.

### Operation

- Open the main valve of the air supply equipment (of your company), and supply the specified pressure.
  - Hold the main unit and aim the nozzle to the workpiece (the object charged with static electricity to be worked upon). Pull the trigger of the main unit, and the color of the indicator light changes from green to blue, and ionized air blows out from the nozzle. The static electricity of the charged object placed into the flow of air is neutralized and removed, and the dust adhering to the object is removed.
- \* If a high voltage abnormality occurs, an alarm status will occur and the indicator light will turn red. At this time, high voltage, air, and lighting LEDs will stop. It will recover if you squeeze the trigger again or turn the power back on. However, unless the abnormal condition is removed, the alarm status will occur again.
- Release the trigger, and the ionized air will stop and the indicator light will change from blue to green.
  - When shutting down this unit, close the main valve of the air supply equipment, and then shut down the power supply.

### \*Details of the function selector switch

Slide the switch cover downward to reveal the function selector switch.

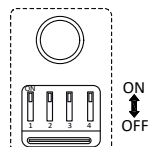

# No.	Function	Switch OFF	Switch ON
1	continuous air and Pulsed air switching	Continuous Air	Pulsed Air
2(* 3)	Pulsed air 5/10 Hz switching	Intermittent air 5Hz	Pulsed air 10 Hz
3	Switching ON/OFF of interlocking with lighting LED	lighting LED Interlocking OFF	lighting LED Interlocking ON
4(* 2)	Switching ON/OFF of delay function of lighting LED	Delay function OFF	Delay function ON

Fig. Inside the switch cover

- \* 1: Switching the No. 2 switch is invalid unless the No. 1 switch is turned ON.
- \* 2: Switching No. 4 is invalid unless No. 3 switch is turned ON.
- \* All switches are OFF at the time of factory shipment.

### About lighting LED

When the lighting LED interlock (switch No. 3) is turned ON, the lighting LED will also turn on/off in conjunction with the ON/OFF of the lever. In addition, when switch No. 4 is turned on, the lighting LED will continue to light up for about 5 seconds even if the lever is turned from ON to OFF (Delay function).

## 8. Maintenance

### Warning

- Before care and maintenance of the unit, make sure to turn OFF the power and air. Otherwise accidents or problems may occur.
- The tip of the discharge needle is sharp, be careful not to touch the discharge needle.
- If this unit was splashed with water, oil, or paint, wipe it clean with a cloth. Especially, when it stuck to the discharge needle and the nozzle inside, wipe it off immediately.
- Contamination of the discharge needle will deteriorate the static removal effect. If deterioration of the static elimination effect is observed, remove the nozzle from the main unit, and clean the discharge needle and its surrounding area.
- Clean the discharge needle regularly about once every two weeks, otherwise optimum charge removal performance may not be obtained and operating problems may occur.
- When dirt accumulates in the inside of the nozzle, clean it, and remove dirt.
- The discharge needle is a consumable part. It is necessary to change the discharge needle when you use this unit for a long term. If operational time is over 20,000 hours, change the discharge needle.
- This unit uses the solenoid valve. The opening/closing life of the solenoid valve is approximately 50 million times. If the air cannot be controlled, stop using it and replace it. Please contact us for replacement of the solenoid valve.
- LED lighting is a consumable part. Depending on usage conditions, the brightness will gradually decrease due to deterioration. If the brightness decreases significantly or the lamp stops lighting, stop using it and replace it. Please contact us for replacement of LED lighting.

### Cleaning Method

- Rotate the nozzle to remove it from the main unit. Clean the discharge needle inside the main unit and the surrounding area by using a cotton swab soaked with alcohol (IPA). Contamination of the tip of the discharge needle will cause the static electricity elimination effect to be deteriorated. After cleaning the needle, restore the nozzle to the original condition and confirm that it is securely attached.

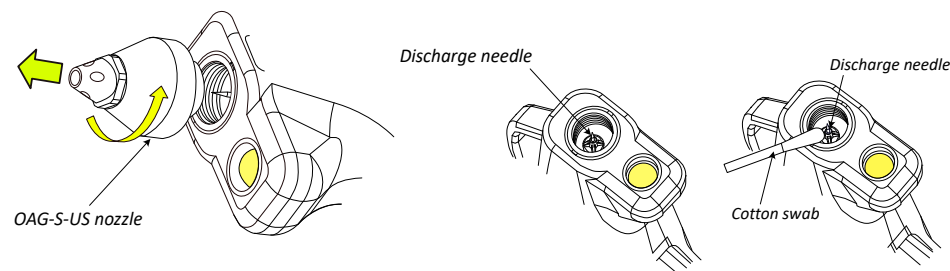

### Replacement of the discharge needle

- The discharge needle is a consumable part and needs to be replaced in time. When replacing the discharge needle unit (DN-W19), use the included discharge needle attachment/detachment tool or radio pliers to remove and attach the discharge needle unit.

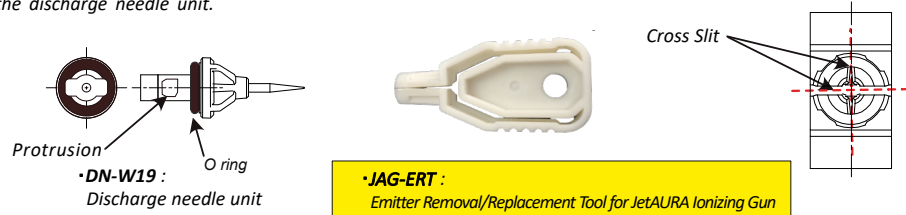

### (1) How to remove the emitter unit

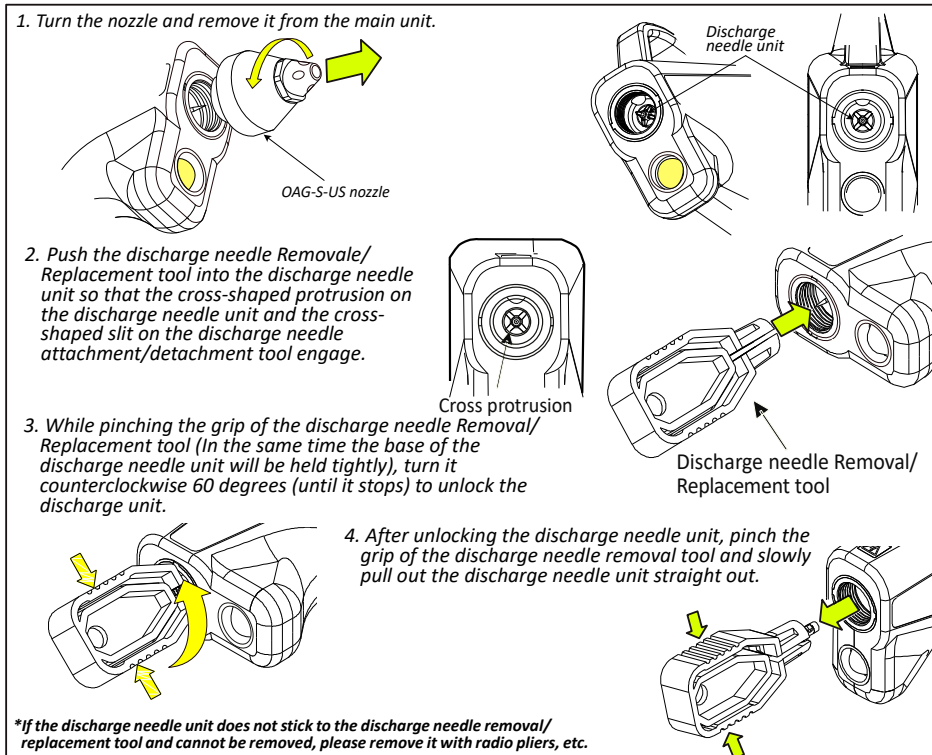

\*If the discharge needle unit does not stick to the discharge needle removal/replacement tool and cannot be removed, please remove it with radio pliers, etc.

### (2) How to install the emitter unit

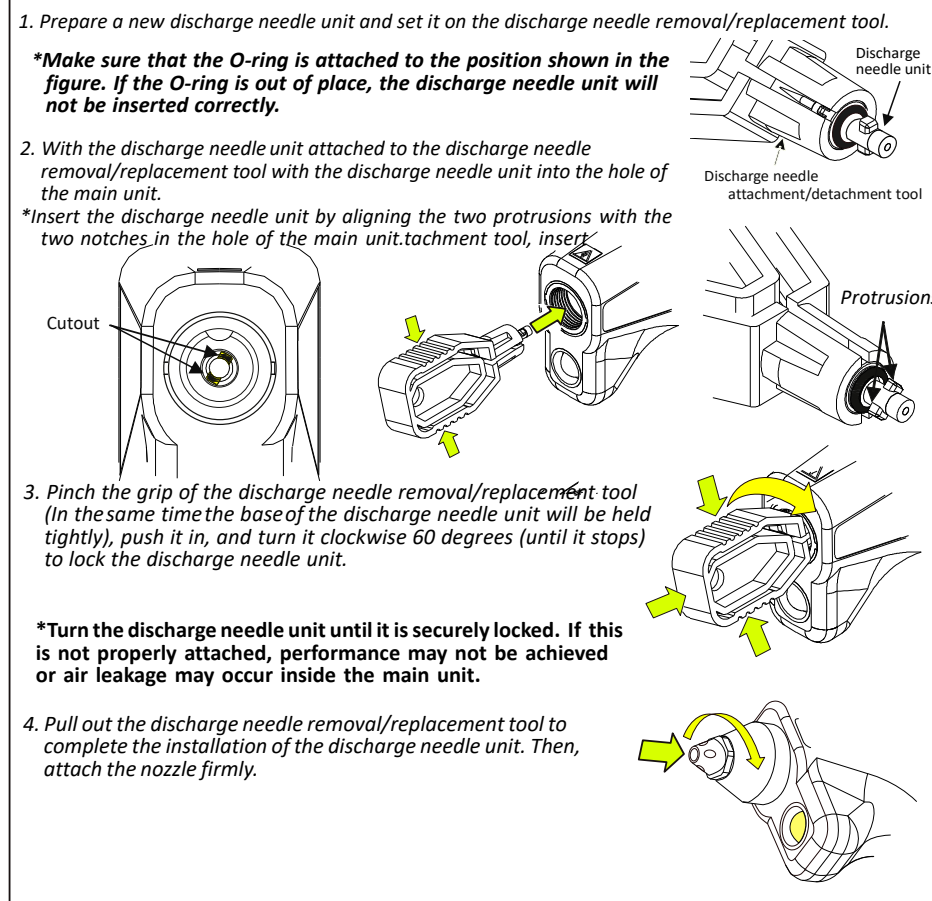

\*Turn the discharge needle unit until it is securely locked. If this is not properly attached, performance may not be achieved or air leakage may occur inside the main unit.

## 9. Troubleshooting

Problem	Main cause	Remedy
The power cannot be supplied to the unit.	The input power is not supplied.	Check the AC adapter to confirm that it is connected to the power source and main unit.
No ionized air is supplied even when you pull the trigger.	The compressed air is not supplied. The Solenoid valve is broken.	Check that compressed air is supplied to the main unit. Contact Static Clean for service/repair.
Alarm LED (red) lights up.	Discharge needle is dirty.	Clean the discharge needle and grounding area of the unit.
	Discharge needle has short-circuited.	Check that there are no foreign objects near the discharge needle.
	Abnormal discharge	Check that the discharge needle is free from foreign objects. Check whether the discharge needle unit is attached to the main unit.
	The nozzle touches to the grounded object. The nozzle is loosening. Supply air pressure is outside the specification range.	Check the nozzle to confirm that it is not touching any grounded object. Tighten the nozzle firmly to the main unit. Supply pressure within the specified range.
Air leak is occurring inside the main unit.	The discharge needle unit is not attached. The function selector switch is not turned on.	Check whether the discharge needle unit is attached to the main unit. Also, check whether the discharge needle unit has an O-ring. Check that switch No. 1 is turned on.
Unable to switch to pulsed air.	Internal circuit is broken. The function selector switch is not turned on.	Contact Static Clean for service/repair. Check that switch No. 3 is turned on.
The lighting LED does not light up.	Internal circuit is broken.	Contact Static Clean for service/repair.

### 10. Cautions

- This unit was designed and manufactured as parts for use in General Industrial Machinery.
- Do not use this unit for any purpose other than charge removal.
- Do not install in an enclosed space, and instead choose a well-ventilated area.
- Do not disassemble or remodel the unit.
- Do not use the nozzle without the internal bushing. This will reduce the static elimination performance.
- Do not insert any foreign objects into the unit. Doing so may result in a short circuit or current leakage, and cause of operator shock.
- If the unit emits any abnormal odors or sounds, smoke, or heat, turn OFF the main power immediately, remove the power cord, and contact your point of purchase. Failure to do so may result in the potential damaged to the unit or a short circuit.
- Do not get the unit wet. If sprinkled with water, or it washes or is used underwater, it will become a cause of the injury by unusual operation, an electric shock, and the potential damage to the unit.
- Do not directly touch the discharge needle with your hands.
- Do not run the wires together with high-voltage lines or power lines or put them in the same raceway.
- This can cause malfunction due to induction.
- Do not use the supplied cable for AC adapter or power cable in this units for a moving section.
- Otherwise, they may break down.
- Avoid cutting or nicking the cable, etc. if the cable is subject to scratching, excessive bending, pulling, rolling up, or being placed under heavy objects or squeezed between two objects, may result in current leaks or defective continuity that leads to electric shocks, or abnormal operation.
- Do not pull out the connectors while the power is ON. Also, do not apply unnecessary stress on the connector. It could result in erratic equipment operation that could lead to personal injury, equipment breakdown, or electrical shocks, etc.
- For safety purposes, power OFF if you plan on not using the unit for an extended period of time.

## Letter of Guarantee

- This unit has passed the inspection carried out by our company. This unit will be subject to repair or replacement, free of charge, of any failed or broken part, if a failure or a breakage should occur during the guarantee period under the condition of normal use, caused by a defect in the design or manufacture by our company.
- The Period of Guarantee: One (1) year starting from the date of delivery.
- Any repair work or replacement for any failure or breakage caused by any of the following reasons will be carried out by the user bearing the cost:
  - Any failure or breakage caused by usage or storage not under the normal condition.
  - Any failure or breakage caused by an unauthorized repair or a modification carried out by other person than our company, or not in accordance with the specifications provided by our company.
  - Any failure or breakage caused by a disaster or force majeure, natural calamity, or an act of God.
  - Any failure or breakage caused by any other reason that cannot be attributable to our company.

Product Name	Ionizing gun (Air gun type Ionizer)	Model Name	JAG-IV JetAURA Ionizing Gun		
Serial Number		Date of Delivery	Inspector		

**STATIC CLEAN INTERNATIONAL**  
 267 Boston Road, Suite# 8 North Billerica, MA 01862  
 Contact: (877) 782-8423 techsales@staticclean.com  
**IF YOU HAVE STATIC, WE HAVE SOLUTIONS.**